

TRENCH FORMER[®] MHD[™] 8 & 12

HEAVY DUTY TRENCH DRAIN FORMING SYSTEMS

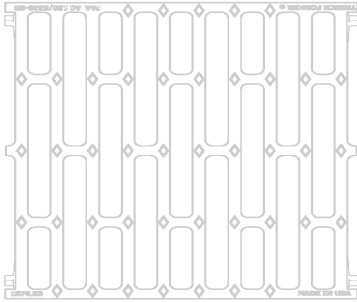

Complies with
FHWA "Buy America"

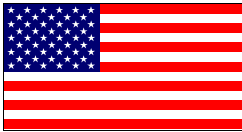

Made in U.S.A.

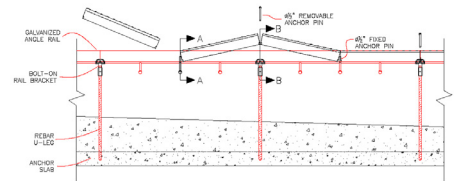

ABT[®], INC.

Advanced Building Technologies



www.abtdrains.com
Today's Hydraulic Solutions

The MHD™ 8 & 12 Technology

ABT, Inc's MHD family of Trench Drains provides the complete assembly of parts needed to handle applications found in municipalities, roadways, the industrial marketplace and other various heavy duty applications. The MHD system goes far beyond a heavy duty grate with its components and features that were designed to offer the best cost of ownership available.

MHD™ System Components

① MHD Heavy Duty Ductile Iron Grates

The MHD's advanced grate design is engineered to provide both performance and appearance. The attractive design provides lighter weight for ease of maintenance and greater inflow area with no sacrifice in strength.

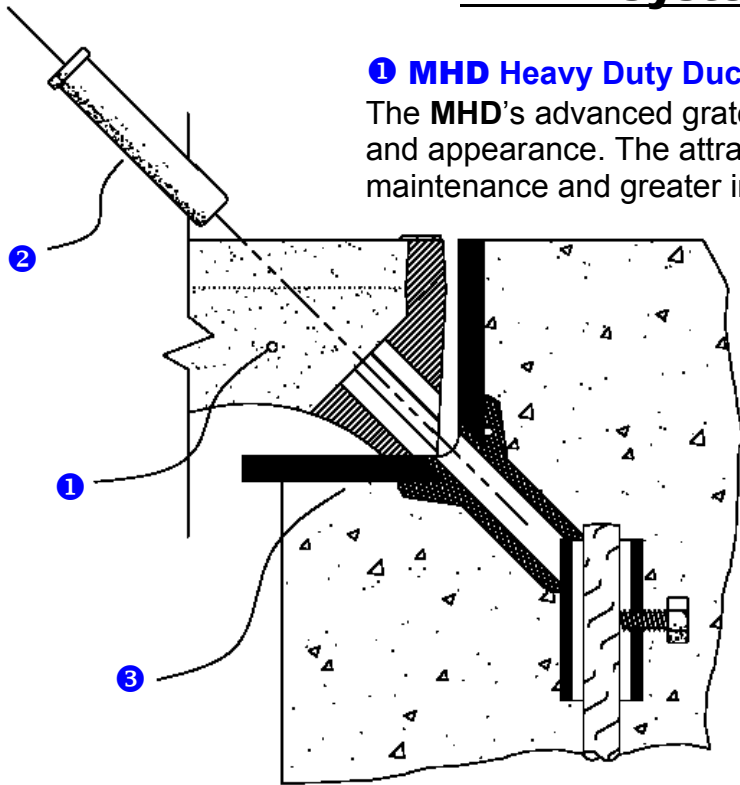

② MHD Four Corner Non-Rigid Grate Retainer System

Utilizing the "Pin Lock System", both longitudinal and vertical retention are achieved. The non-rigid "Pin Lock System" eliminates the thermal induced stresses in the typical bolt down assemblies that cause concrete cracking. The pins do not become loose and back out as bolts do. Although four pins are used for retention, only one pin per grate must be removed for maintenance.

③ MHD Frame Design

The MHD systems ASTM A-36 Structural Steel frame maximizes strength and load transference into the encapsulation concrete. MHD does not utilize liners that create the failure liability by being sandwiched between the frame and concrete... such liner systems propagate failures by their low compressive strength, creep, and thermal expansion properties.

Design Flexibility

The MHD Systems Expanded Poly Styrene (E.P.S.) formers can be configured for the Designer's special flow and depth requirements. A large range of trench depths, slopes, profiles and configurations provides the Designer with greater flexibility for challenging projects. Additionally, the system is pre-engineered and factory fabricated reducing the potential for construction error in the field.

Inspectability & Constructability

The MHD systems are easily inspected after concrete placement. Prior to service, inspection for voids below the frame can be observed and repaired. Such voids are concealed by other systems and will eventually lead to frame collapse. The MHD system installs easily and quickly as compared to traditional Cast-In-Place trenches.

MHD™ 8 & 12 (Formerly MD200™ / MHD200™ & MD300™ / MHD300™)

Technical Data

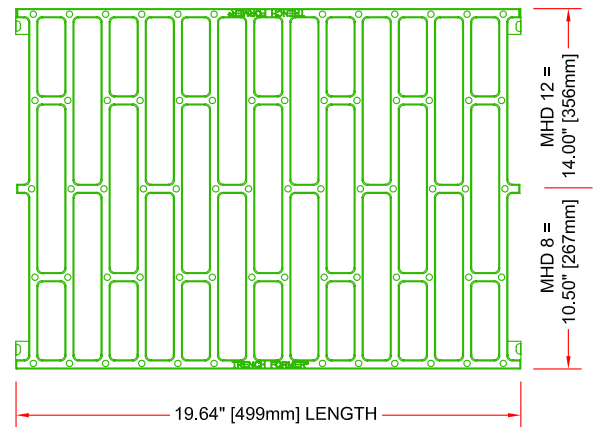
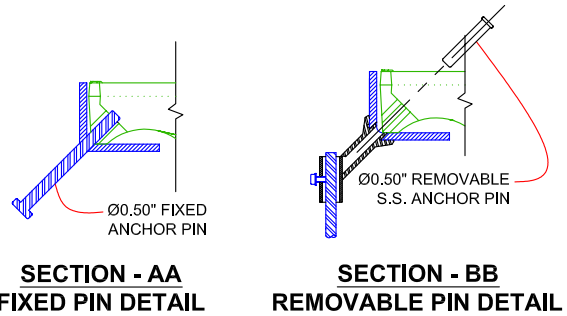
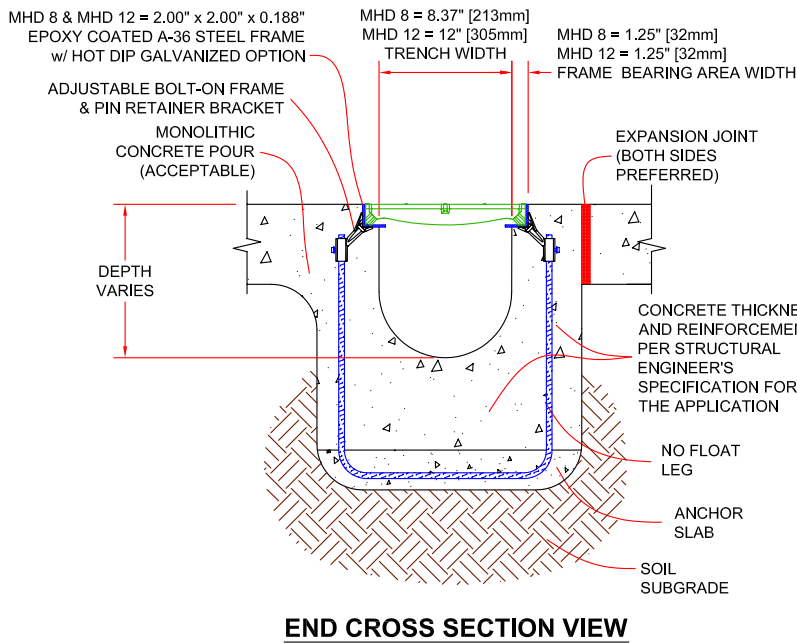
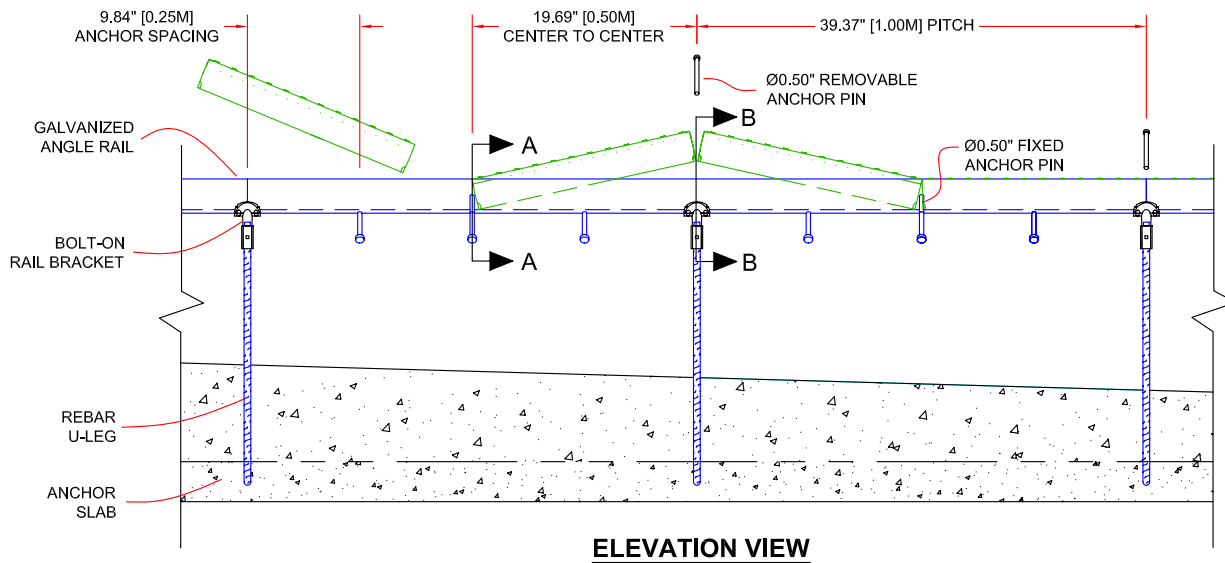

DATA

- Grate Proof Strength - Exceeds all Federal and AASHTO Regs.
- Vertical Grate Restraint - 2,000 Lbs.
- Longitudinal Grate Restraint - 10,000 Lbs.
- Frames are ASTM A-36 Structural Steel
- All parts are made in U.S.A. and comply FHWA's "Buy America" Policies
- For Hydraulic Capacity for specific conditions, Drawings, Specifications, and other information; go to www.abtdrains.com

DISCLAIMER: The customer and the customer's architects, engineers, consultants and other professionals are completely responsible for the selection, installation, and maintenance of any product purchased from ABT, and EXCEPT AS EXPRESSLY PROVIDED IN ABT'S STANDARD WARRANTIES, ABT MAKES NO WARRANTY, EXPRESS OR IMPLIED, AS TO THE SUITABILITY, DESIGN, MERCHANTABILITY, OR FITNESS OF THE PRODUCT FOR CUSTOMER'S APPLICATION. Copies of ABT's standard warranties are available upon request. Trench Former® is a registered trademark of ABT, Inc.® USA Patent Numbers 5,281,051; 5,348,421; 5,393,171; 5,399,047; 5,573,350; 5,702,204; 5,890,839; 6,443,656; 6,533,497; 6,926,245 : Canada 2,080,136; 2,131,866; 2,131,867; 2,139,405; 2,139,407 : Mexico 189,218; 189,436; 197,851 : Other US and foreign patents pending.

Designed Right, Engineering that saves... Life Safety, Life Cycle...

Pre-Engineered E.P.S. Forms:

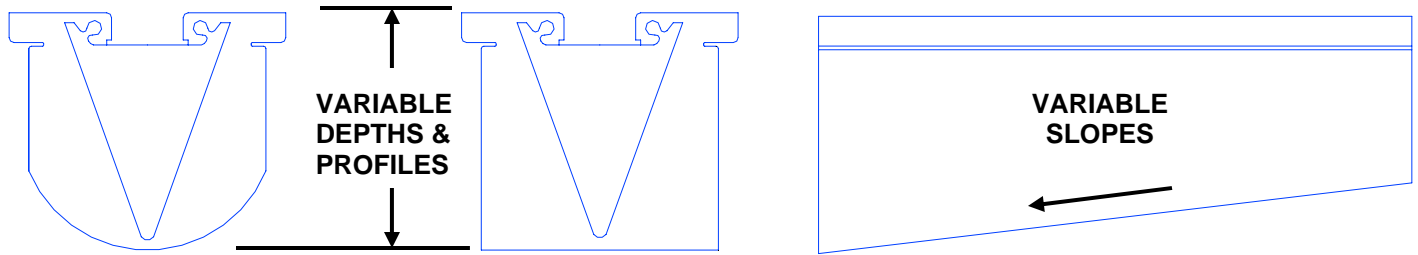

MHD's E.P.S. Foam Former design flexibility allows the designer to select various system slopes, depths and section profiles to meet their specific requirements, site restrictions and hydraulics.

Design Notes:

- Typical Frame sections are 6.56' [2M]. Frames are also available in 3.28' [1M] & 1.64' [0.5M]
- Auxiliary Frames are available to facilitate "T's", "L's", Intersections, Radii and Joints.
- All MHD system grates are 19.64" [0.5M] in length, widths vary per system.



**Call or E-mail us today and ask for our interactive hydraulic calculator

For more information and design tools go to www.abtdrains.com

- Hydraulic Design Guide
- Specification Generator
- PDF Catalogs & Details
 - Plan Notes
- Performance Specifications
- ACAD Drawings & Details
- Additional Product Info
 - Installation Guides

ABT, INC.

P.O. Box 837, 259 Murdock Road, Troutman, NC 28166
800-438-6057 * 704-528-9608 * Fax: 704-528-5478
Visit us @ www.abtdrains.com