

2552A
ONE PIECE

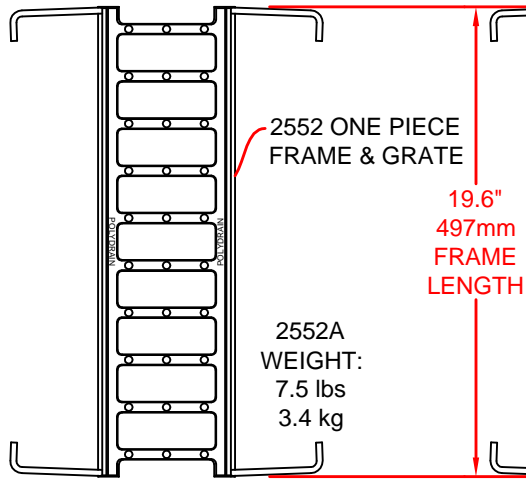

2552A
WEIGHT:
7.5 lbs
3.4 kg

PLAN

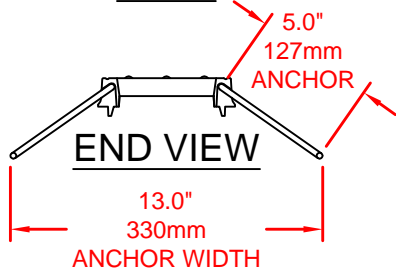

2542A
FRAME / GRATE ASSEMBLY

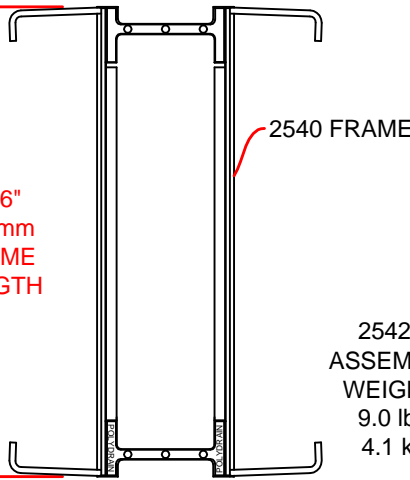

2542A
ASSEMBLY
WEIGHT:
9.0 lbs
4.1 kg

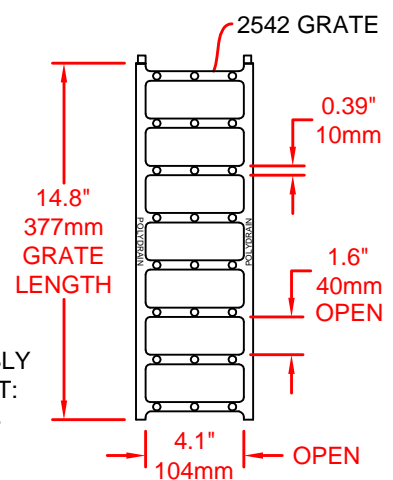

PLAN

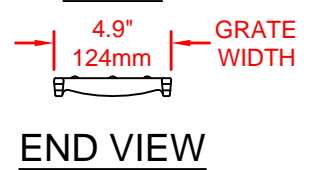

PLAN

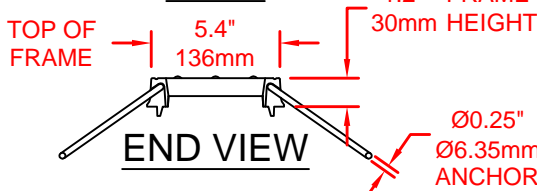

FRAME & GRATE MATERIAL:
ASTM A536 Grade 65-45-12 DUCTILE IRON

INLET AREA: 67%
0.0828 sq. meters / linear meter
0.27 sq. ft / linear foot

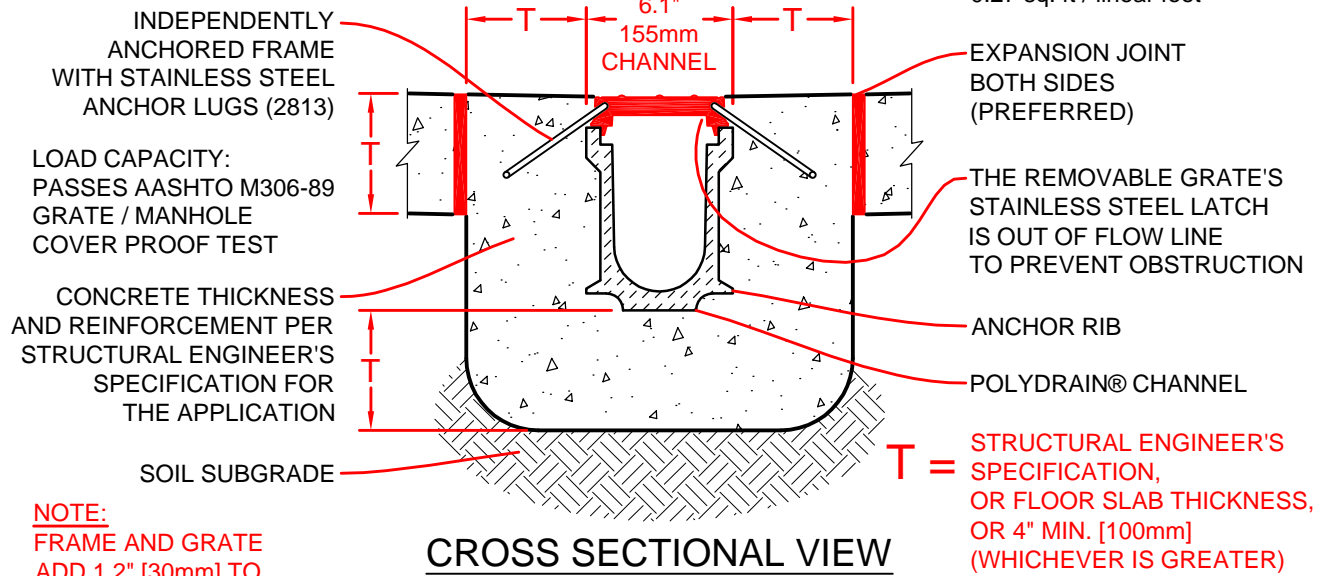

NOTE:
FRAME AND GRATE ADD 1.2" [30mm] TO OVERALL DEPTH OF CHANNEL



P.O. BOX 837, 259 MURDOCK ROAD
TROUTMAN, NC 28166
(704) 528-9806

SPECIFICATION DRAWING © 2002 ABT, Inc.

INTERCEPTOR® A-67
ONE PIECE & FRAME / GRATE ASSEMBLY

FILE: **S-2552A-00**

PART: **2552A, 2542A**

Proprietary rights of ABT, Inc. are included in the information disclosed herein. The recipient, by accepting this document, agrees that neither this document nor the information disclosed herein nor any part thereof shall be copied, reproduced or transferred to others for manufacturing or for any other purpose except as specifically authorized in writing by ABT, Inc.

DISCLAIMER: The customer and the customer's architects, engineers, consultants and other professionals are completely responsible for the selection, installation, and maintenance of any product purchased from ABT, and EXCEPT AS EXPRESSLY PROVIDED IN ABT'S STANDARD WARRANTIES, ABT MAKES NO WARRANTY, EXPRESS OR IMPLIED, AS TO THE SUITABILITY, DESIGN, MERCHANTABILITY, OR FITNESS OF THE PRODUCT FOR CUSTOMER'S APPLICATION. Copies of ABT's standard warranties are available upon request.