

INSTALLATION INSTRUCTIONS PDX® - TOGGLE LOCK

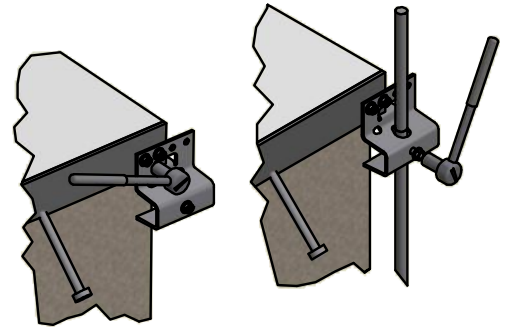

2. LEG ATTACH

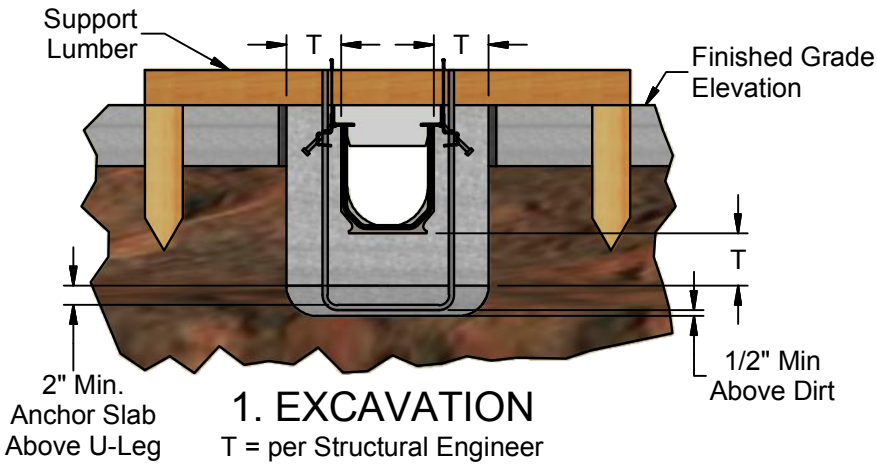
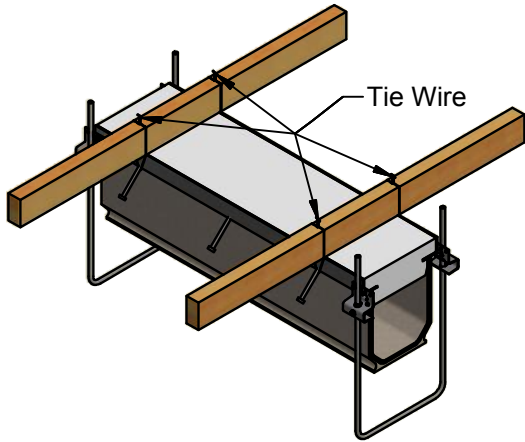

3. SUPPORT LUMBER ATTACH

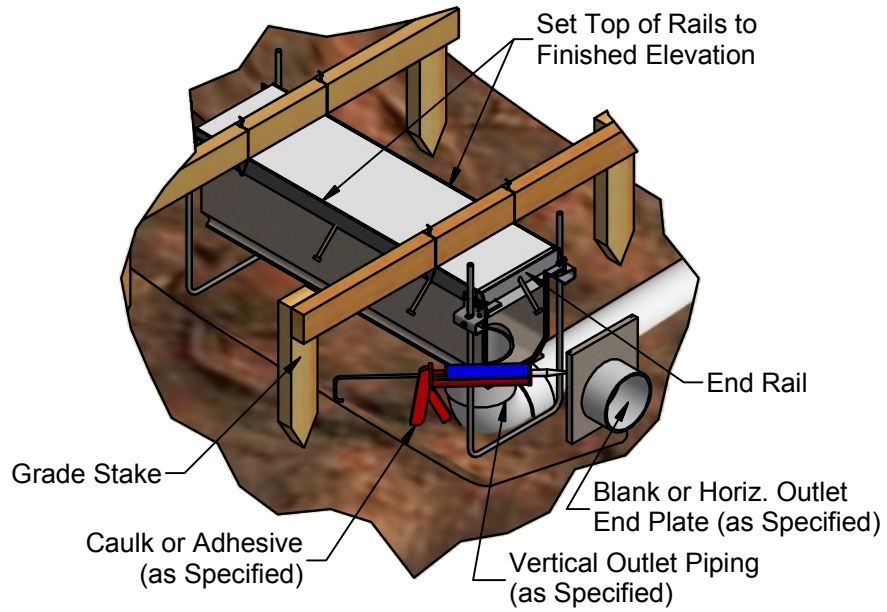

4. DISCHARGE PLACE & ALIGN

Locate and Align Outlet Channel First. Start at Deep End and Work to Shallow End.

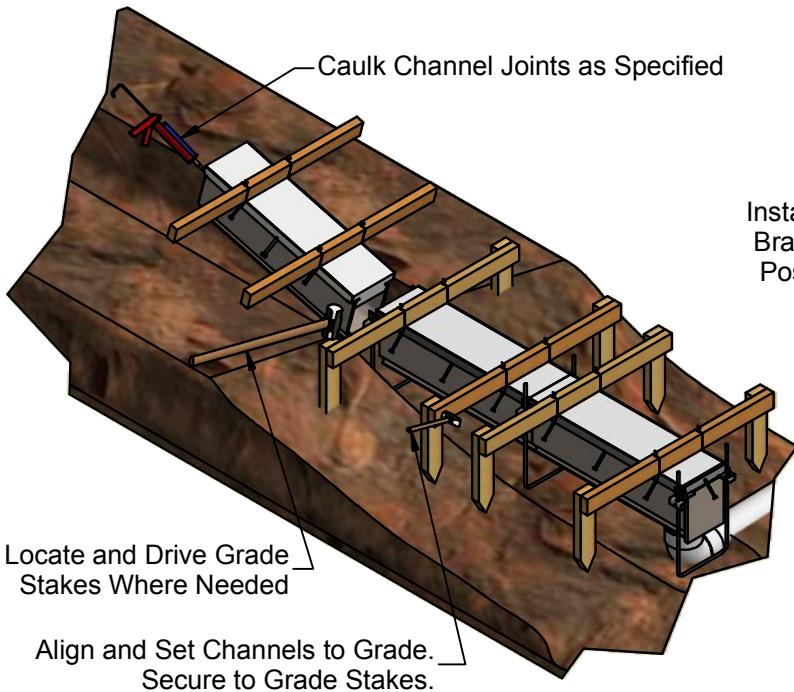

5. CHANNEL PLACE & ALIGN

Install Remaining Leg Bracket Screws After Positioning Channels

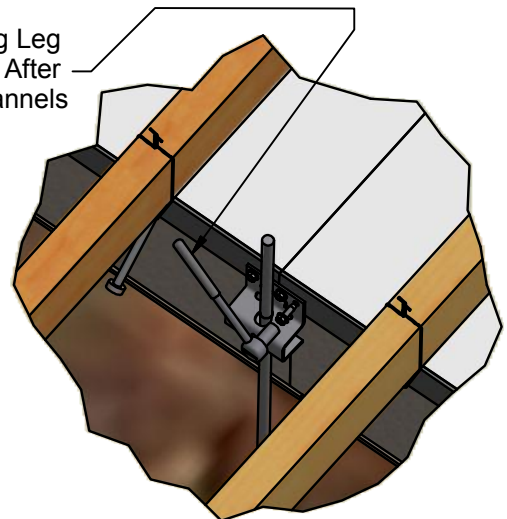

6. RAIL CONNECTION

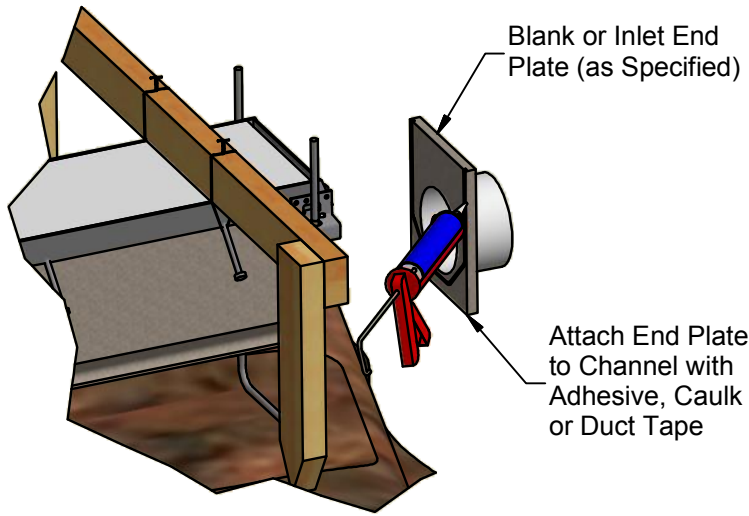

7. END PLATE

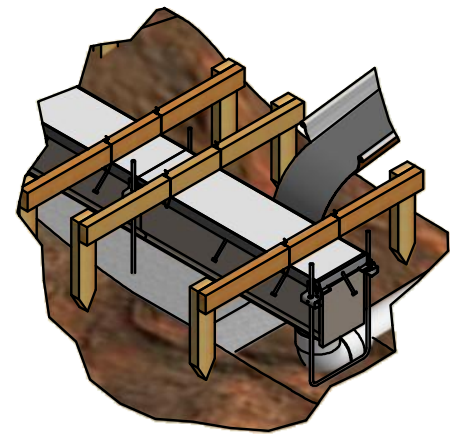

8. PLACE ANCHOR SLAB

See Step 1 for Dimensions

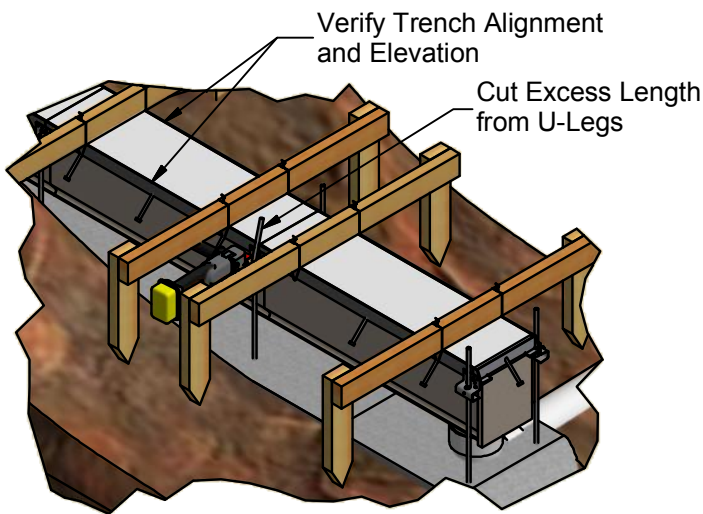

9. FINAL ALIGN & U-LEG TRIM

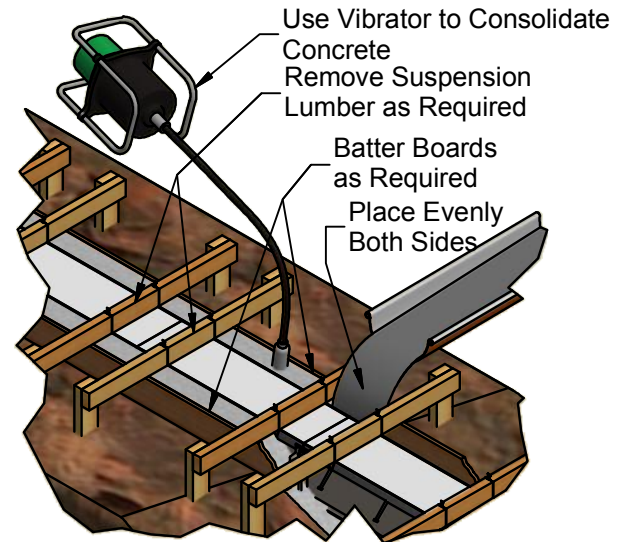

10. ENCAPSULATION CONCRETE PLACEMENT & CONSOLIDATION

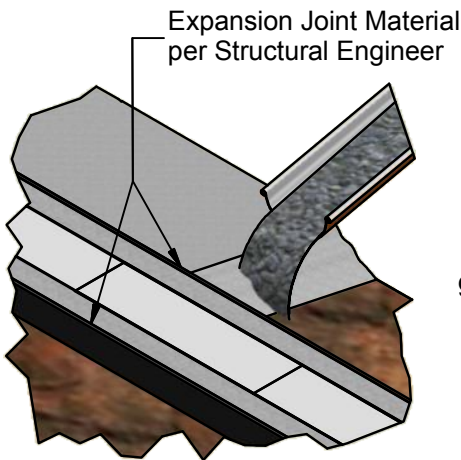

11. FLOOR CONCRETE PLACEMENT

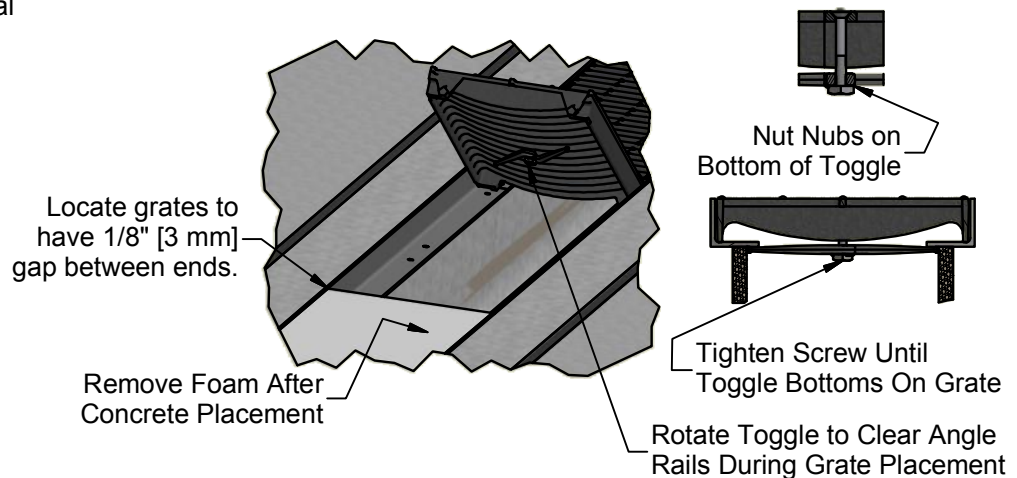

12. GRATE INSTALLATION

ABT, Inc.[®]

259 Murdock Road, P.O. Box 837
Troutman, NC 28166
abtdrains.com 1-800-438-6057

ABT's warranties are void if components or installation procedures are modified.

ver. 6/1/15